

Worship Center: Sanctuary *(Page 1 of 5)*

Church/Organization: _____ Dates and times of use
 Retreat Date: _____ 1. _____
 Group size: _____ 2. _____

Please indicate the function of this meeting room:

Meeting Room Classroom/workshop Other: _____

Room Set-Up: Worship Center

The main sanctuary of the worship center is set-up with traditional pews that can accommodate groups of 225. Additional seating is available upon request. Maximum additional chairs: 175

Number of tables: _____ Number of chairs: _____ Lectern: Yes No
 Small group set-up (if applicable): Number of groups: _____ Chairs per group: _____

Audio/visual set-up

Available Equipment

- Sound System
- Twenty Four Channel Mixer
- Wireless Microphone System
 - Two Hand Held Wireless Microphone
 - Two Lavalier Wireless Microphone
- Live Recording
 - Mission Springs is not responsible for providing CD/CD-R/CD-RW
- Video Projector & Retractable Screen
- VHS, DVD & CD Capabilities
- VGA & RCA Interfaces
- Grand Piano

Special Request Equipment

- Microphone Sets: quantity _____ (max 10)
- Music Stands: quantity _____ (max 8)
- Monitors: quantity: _____ (max 2)
- Whiteboard & Markers
- Flipchart

Please list equipment group will be bringing:

Worship Center: Rooms 3 & 4 (Page 2 of 5)

Church/Organization: _____

Dates and times of use

Retreat Date: _____

1. _____

Group size: _____

2. _____

Please indicate the function of this meeting room:

Meeting Room

Classroom/workshop

Other: _____

Room Set-Up: Worship Center Room 3

Please indicate the desired set-up format. If a custom set-up is desired, please draw on the meeting room layout page (4 of 5).

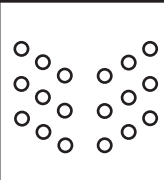
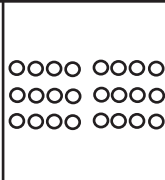
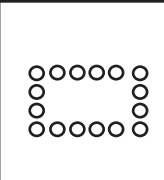
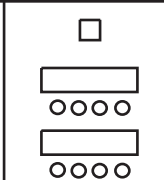
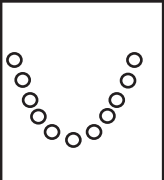
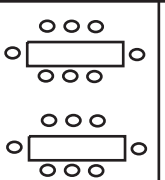
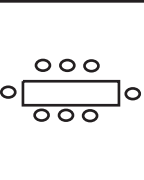
Chevron	Theater	Reception	Classroom	Semi-Circle	Craft	Board Room
						
<input type="checkbox"/> Max 20	<input type="checkbox"/> Max 25	<input type="checkbox"/> Max 25	<input type="checkbox"/> Max 10	<input type="checkbox"/> Max 15	<input type="checkbox"/> Max 20	<input type="checkbox"/> Max 12

Number of tables: _____

Number of chairs: _____

Lectern: Yes No

Small group set-up (if applicable):

Number of groups: _____

Chairs per group: _____

Room Set-Up: Worship Center Room 4

Please indicate the desired set-up format. If a custom set-up is desired, please draw on the meeting room layout page (4 of 5).

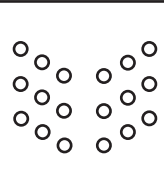
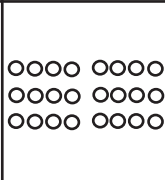
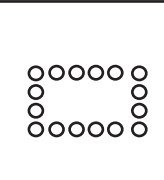
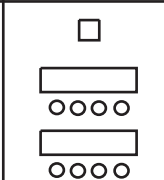
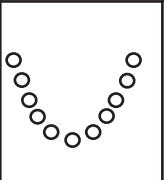
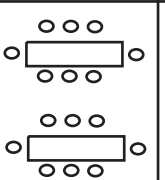
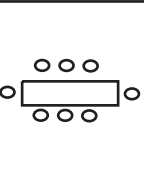
Chevron	Theater	Reception	Classroom	Semi-Circle	Craft	Board Room
						
<input type="checkbox"/> Max 20	<input type="checkbox"/> Max 25	<input type="checkbox"/> Max 25	<input type="checkbox"/> Max 10	<input type="checkbox"/> Max 15	<input type="checkbox"/> Max 20	<input type="checkbox"/> Max 12

Number of tables: _____

Number of chairs: _____

Lectern: Yes No

Small group set-up (if applicable):

Number of groups: _____

Chairs per group: _____

Worship Center: Rooms 5, 6, 7, 8 (Page 3 of 5)

Church/Organization: _____

Dates and times of use

Retreat Date: _____

1. _____

Group size: _____

2. _____

Please indicate the function of this meeting room:

Meeting Room

Classroom/workshop

Other: _____

Room Set-Up: Worship Center Rooms 5, 6, 7, 8

The upstairs meeting rooms of the worship center (5-8) can be divided into 1 to 4 classrooms. Maximum capacity is 80.

Please indicate the number of classrooms: _____ (Max 4)

Please indicate set-up format. If a custom set-up is desired, please draw on the meeting room layout page (5 of 5).

Room Configuration	Number of Chairs	Number of Tables	Set-up Style	Lectern (Yes or No)
<input type="checkbox"/> RM 5, 6, 7, 8				
<input type="checkbox"/> RM 5				
<input type="checkbox"/> RM 6				
<input type="checkbox"/> RM 7				
<input type="checkbox"/> RM 8				
<input type="checkbox"/> RM 5 & 7				
<input type="checkbox"/> RM 6 & 8				
<input type="checkbox"/> RM 5 & 6				
<input type="checkbox"/> RM 7 & 8				

Set-Up Styles

Layout	Chevron	Theater	Reception	Classroom	Semi-Circle	Craft	Board Room
RM 5, 6, 7, 8	<input type="checkbox"/> Max 80	<input type="checkbox"/> Max 80	<input type="checkbox"/> Max 80	<input type="checkbox"/> Max 40	<input type="checkbox"/> Max 80	<input type="checkbox"/> Max 80	<input type="checkbox"/> Max 80
RM 5	<input type="checkbox"/> Max 20	<input type="checkbox"/> Max 20	<input type="checkbox"/> Max 20	<input type="checkbox"/> Max 10	<input type="checkbox"/> Max 10	<input type="checkbox"/> Max 12	<input type="checkbox"/> Max 12
RM 6	<input type="checkbox"/> Max 20	<input type="checkbox"/> Max 20	<input type="checkbox"/> Max 20	<input type="checkbox"/> Max 10	<input type="checkbox"/> Max 10	<input type="checkbox"/> Max 12	<input type="checkbox"/> Max 12
RM 7	<input type="checkbox"/> Max 20	<input type="checkbox"/> Max 20	<input type="checkbox"/> Max 20	<input type="checkbox"/> Max 10	<input type="checkbox"/> Max 10	<input type="checkbox"/> Max 12	<input type="checkbox"/> Max 12
RM 8	<input type="checkbox"/> Max 20	<input type="checkbox"/> Max 20	<input type="checkbox"/> Max 20	<input type="checkbox"/> Max 10	<input type="checkbox"/> Max 10	<input type="checkbox"/> Max 12	<input type="checkbox"/> Max 12
RM 5 & 7	<input type="checkbox"/> Max 40	<input type="checkbox"/> Max 40	<input type="checkbox"/> Max 40	<input type="checkbox"/> Max 20	<input type="checkbox"/> Max 40	<input type="checkbox"/> Max 40	<input type="checkbox"/> Max 24
RM 6 & 8	<input type="checkbox"/> Max 40	<input type="checkbox"/> Max 40	<input type="checkbox"/> Max 40	<input type="checkbox"/> Max 20	<input type="checkbox"/> Max 40	<input type="checkbox"/> Max 40	<input type="checkbox"/> Max 24
RM 5 & 6	<input type="checkbox"/> Max 40	<input type="checkbox"/> Max 40	<input type="checkbox"/> Max 40	<input type="checkbox"/> Max 20	<input type="checkbox"/> Max 40	<input type="checkbox"/> Max 40	<input type="checkbox"/> Max 24
RM 7 & 8	<input type="checkbox"/> Max 40	<input type="checkbox"/> Max 40	<input type="checkbox"/> Max 40	<input type="checkbox"/> Max 20	<input type="checkbox"/> Max 40	<input type="checkbox"/> Max 40	<input type="checkbox"/> Max 24

Number of tables: _____

Number of chairs: _____

Lectern: Yes No

Small group set-up (if applicable):

Number of groups: _____

Chairs per group: _____

WORSHIP CENTER

Meeting Rooms

1, 2, 3, 4

(Page 4 of 5)

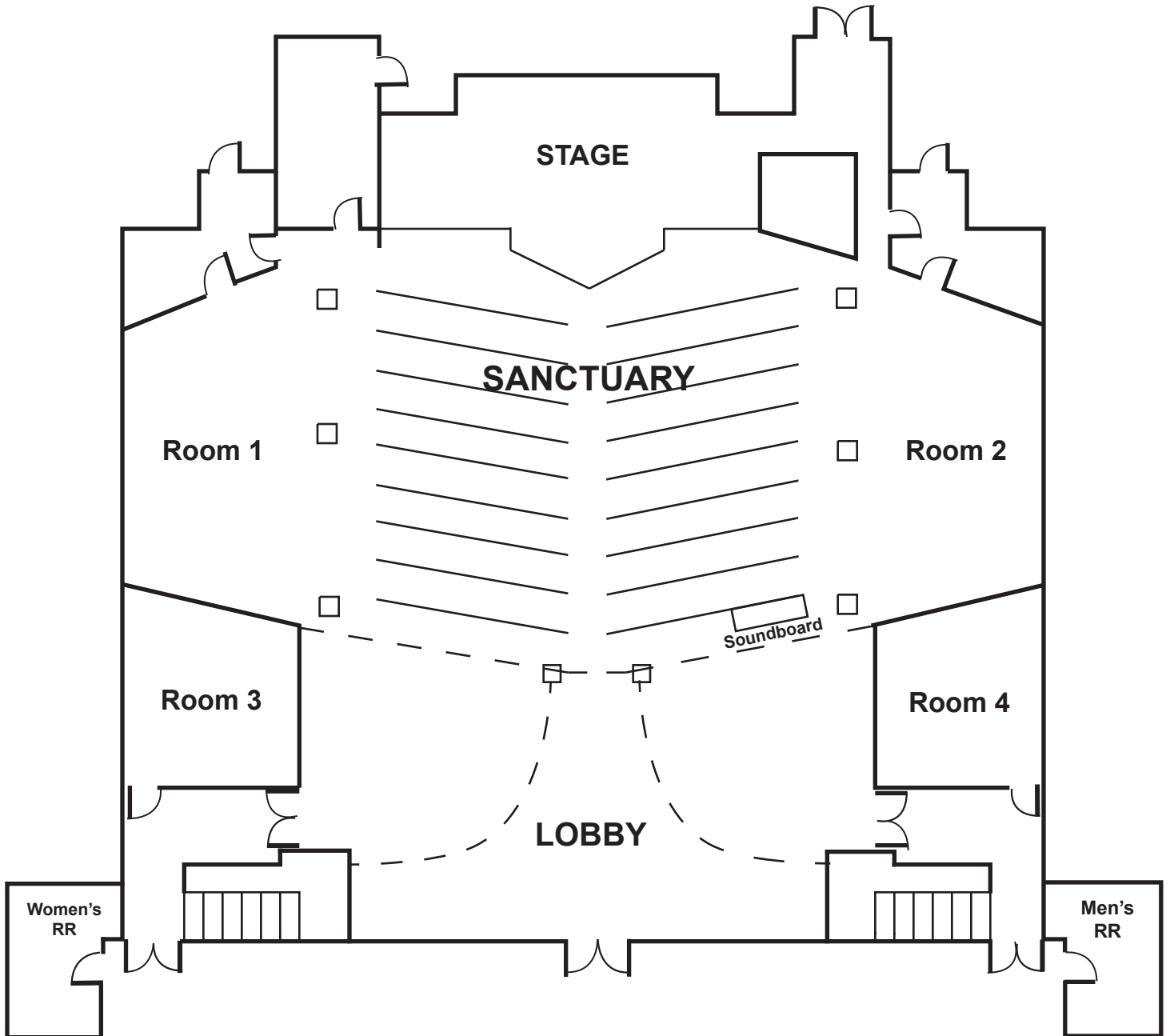

WORSHIP CENTER

Upstairs Meeting Rooms

5, 6, 7, 8

(Page 5 of 5)

